

	UC OBSERVATORIES	K1DM3		KECK 1 DEPLOYABLE TERTIARY MIRROR	
	DRAWN: SANDFORD			LE0400 Inner Drum	
	ENGR: SANDFORD			Inner Drum - overview	
	872-LE0400-InnerDrum_r00.Prj Pcb			872-LE0400-1	
872-LE0400-1-InnerDrum_main.SchDoc			REV 00	B	1/5

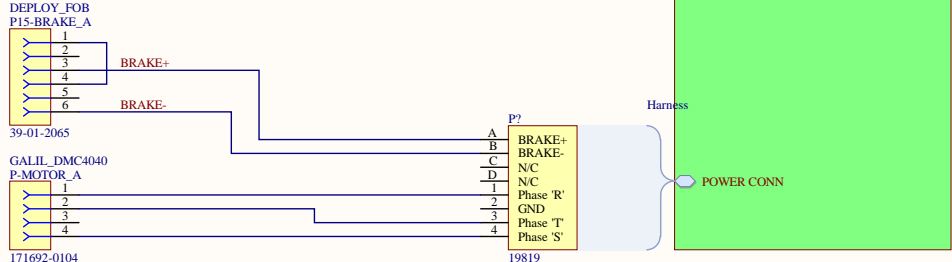

	UC OBSERVATORIES	K1DM3	KECK 1 DEPLOYABLE TERTIARY MIRROR
	DRAWN: SANDFORD		LE0400 Inner Drum
	ENGR: SANDFORD		Inner Drum - Actuator A
	872-LE0400-InnerDrum_r00.PrlPcb		872-LE0400-2
	872-LE0400-2-ActuatorA_SchDoc	REV 00	B 2/5

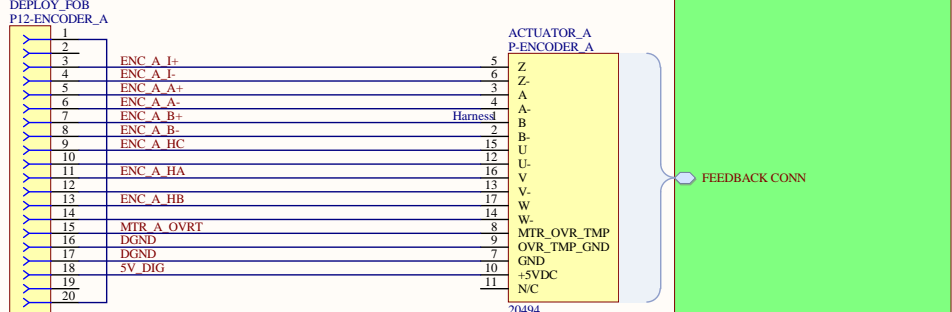
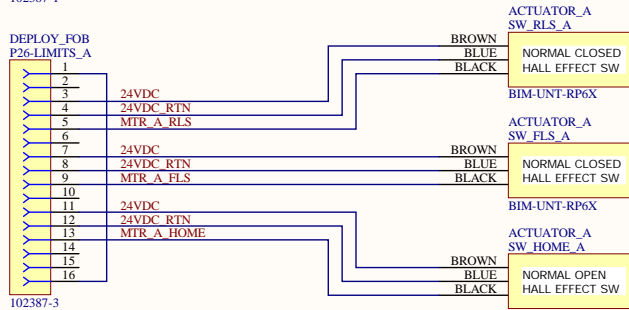
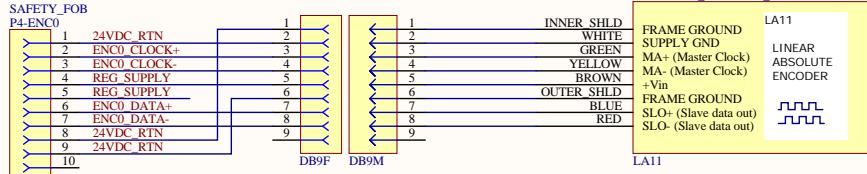
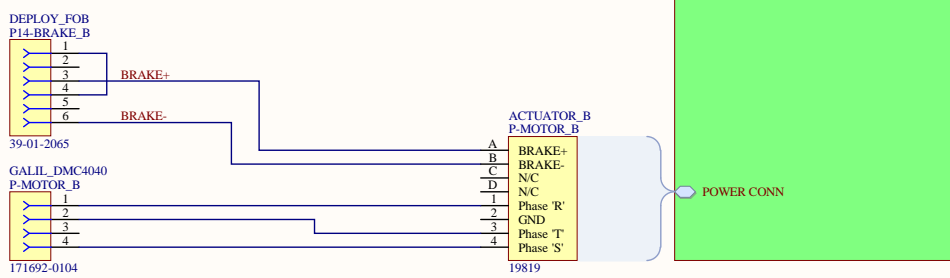
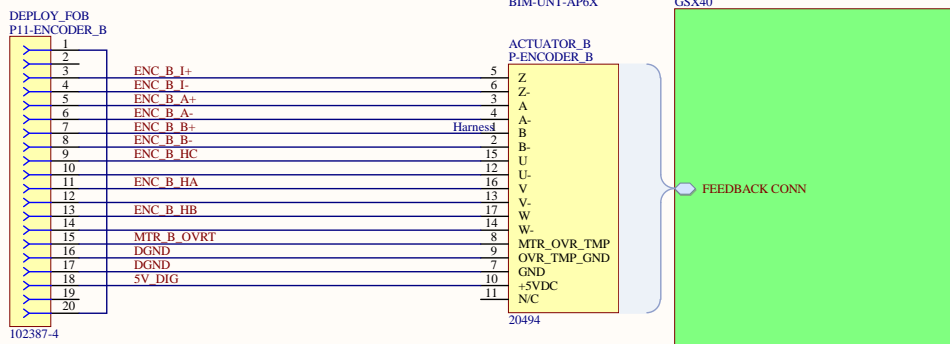
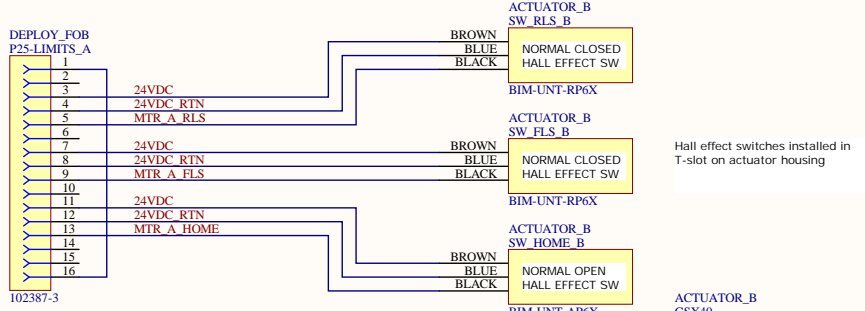
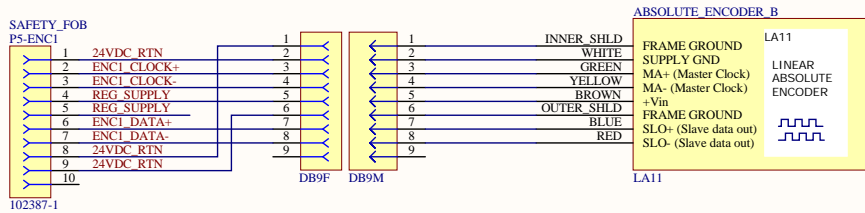

	UC OBSERVATORIES	K1DM3	KECK 1 DEPLOYABLE TERTIARY MIRROR
	DRAWN: SANDFORD		LE0400 Inner Drum
	ENGR: SANDFORD		Inner Drum - Actuator B
	872-LE0400-InnerDrum_r00.PrtPcb		872-LE0400-3
872-LE0400-3-ActuatorB_SchDoc	REV 00	B	3/5

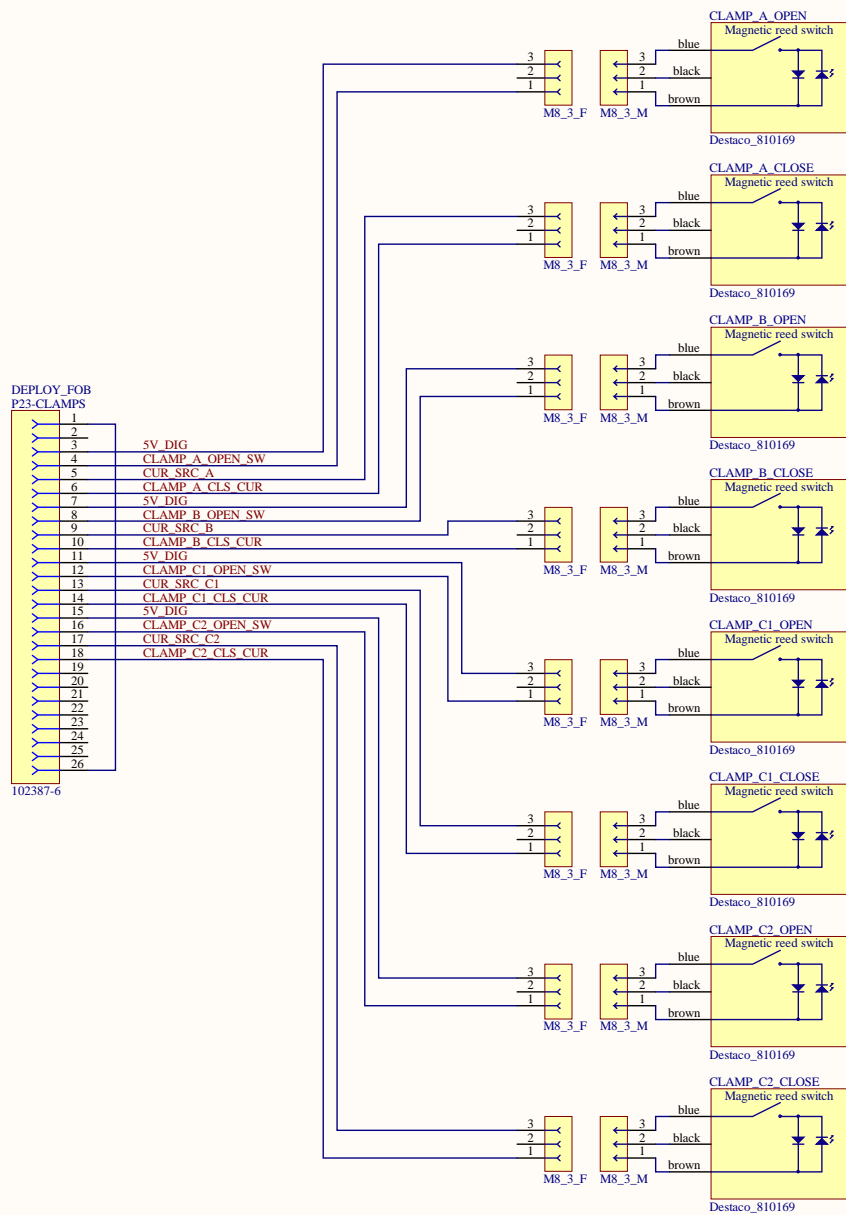

Destaco 810169 Magnetic Reed Switches
 Delivered with .15m pigtail
 terminated with M8 3-pin male
 Installed in groove on clamp cylinders

Extension cables
 female M8 3-pos

Pigtail and extension cable wire colors
 pin-1 blue wire
 pin-2 black wire
 pin-3 brown wire

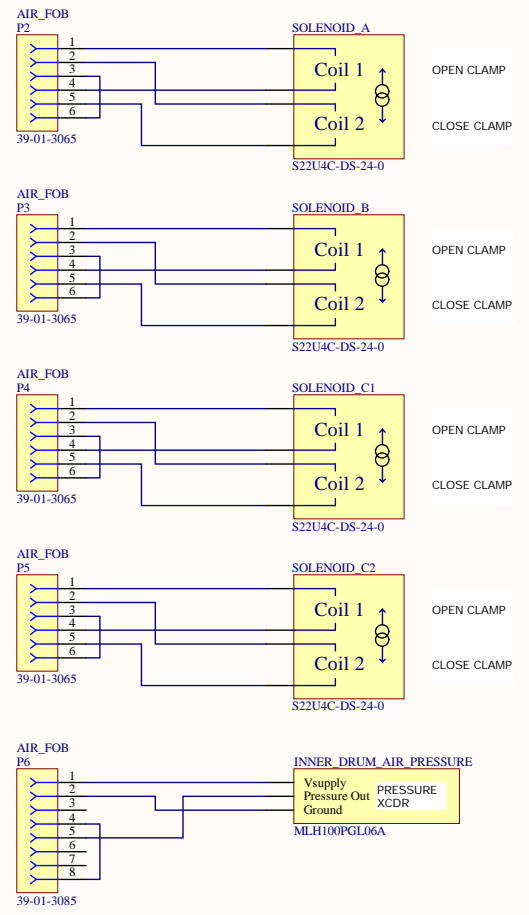

	UC OBSERVATORIES	K1DM3	KECK 1 DEPLOYABLE TERTIARY MIRROR	
	DRAWN: SANDFORD		LE0400 Inner Drum	
	ENGR: SANDFORD		Inner Drum - clamp switches and solenoids	
	872-LE0400-InnerDrum_r00.PrjPcb 872-LE0400-4-Clamps.SchDoc		872-LE0400-4	REV 00

K1DM3 Inner Drum Signal Contact Block View facing contact block from the outside of outer drum

Contact blocks
all contact block locations wired in parallel (daisy chained)
connection to contact blocks are screw terminals embedded in blocks

Signal contacts
AWG 24 stranded Cat 5e
(2) Cat 5e cables
-1 for Ethernet
-2 for remaining signals

Power contacts
14 AWG stranded

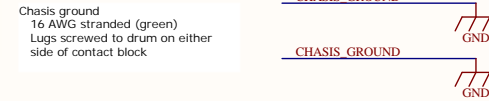
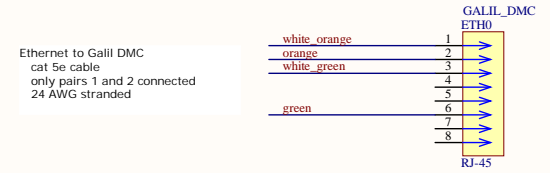
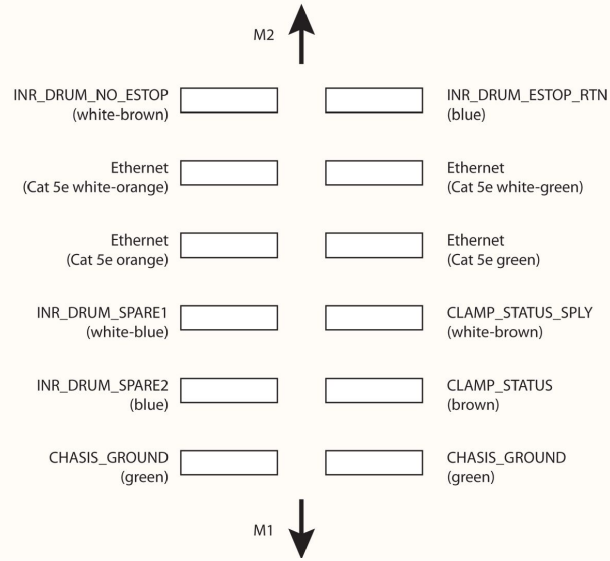

K1DM3 Inner Drum Power Contact Block View facing contact block from the outside of outer drum

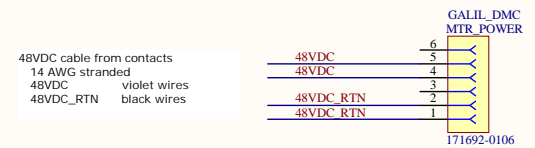
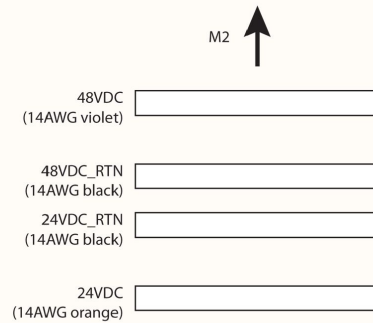

	<i>UC OBSERVATORIES</i>	K1DM3	KECK 1 DEPLOYABLE TERTIARY MIRROR
	DRAWN: SANDFORD ENGR: SANDFORD		LE0400 Inner drum
	Inner Drum - contacts to outer drum		
	872-LE0400-5-Contacts.SchDoc		872-LE0400-5