

MOTOR WIRE REMOVED FROM STAGE CABLES

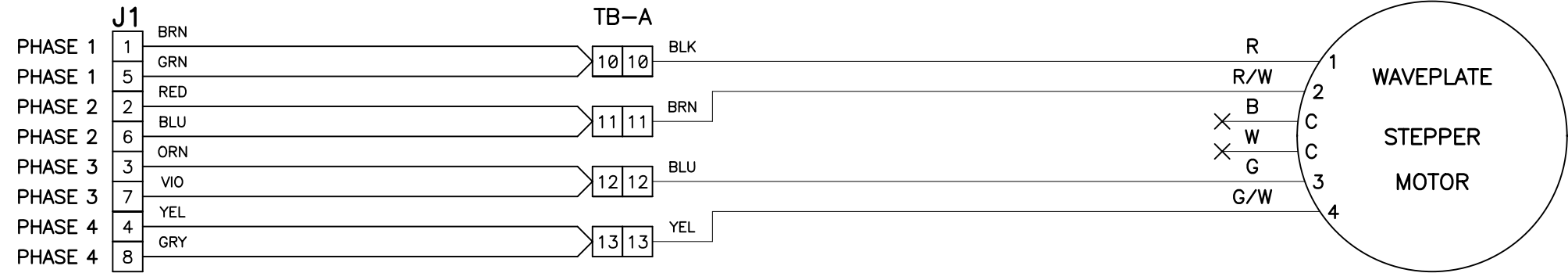

AXIS - 1A

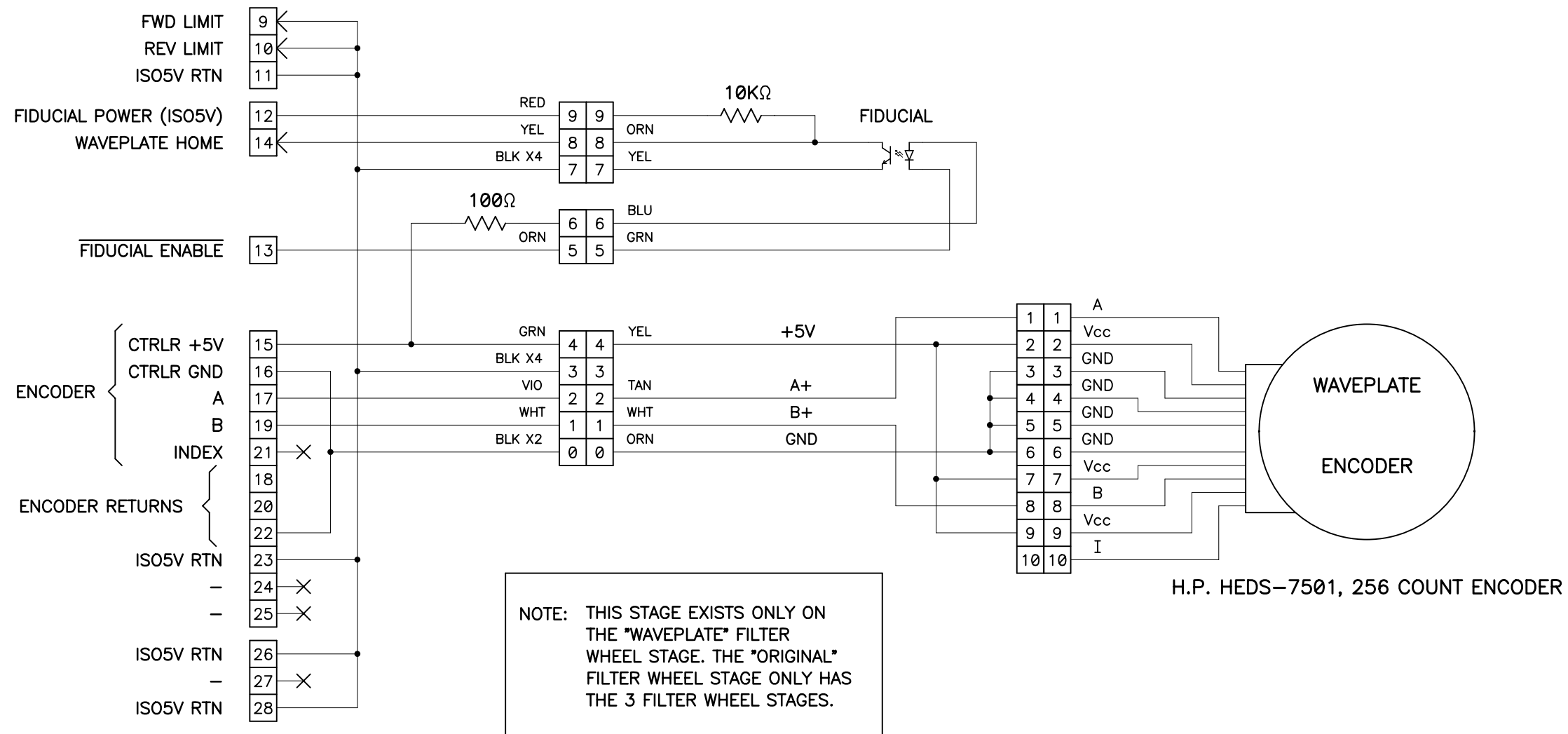

NOTE: THIS STAGE EXISTS ONLY ON THE "WAVEPLATE" FILTER WHEEL STAGE. THE "ORIGINAL" FILTER WHEEL STAGE ONLY HAS THE 3 FILTER WHEEL STAGES.

AMP CPC 17-28

NOTE: ENCODER SIGNALS AND FIDUCIAL ENABLE SIGNALS ARE REFERENCED TO GALIL CONTROLLER POWER SUPPLY

REVISIONS	http://loel.ucolick.org/manual/KAST/schematics/KAST_Waveplate_sh_2.pdf
06-27-06	REV. B - TRANSALTED INTO PCAD, UPGRADE TO GALIL CONTROLLER
01-24-08	UPDATED TO GALIL DMC-4000 CONTROLLER
04-21-08	ADDED TWISTED PAIRS
05-02-08	MOVED HOME SENSOR LED POWER TO GALIL POWER SUPPLY FOR PROPER REFERENCE
01-23-09	UPDATED TERMINAL STRIPS, WIRING & LIMIT FOR PROPER REFERENCE
02-17-09	GROUNDING BOTH CW & CCW LIMITS TO ISO-GND AT PINS 9 & 10 OF J1. ADDED ENCODER INFO.
02-27-09	ADDED WIRE COLORS

UNIVERSITY OF CALIFORNIA LICK OBSERVATORY		WAVEPLATE STAGE KAST SPECTROGRAPH	
DES'N BY: T. Ricketts, B. Alcott	ORIGIN DATE: 06-05-06	DWG. NO. EL-3711	NUM. 2 OF 2
Last SN	MODIFY DATE: 02-27-09	REV. B	
PRINT TIME: 08:25:11	PRINT DATE: Tue Mar 10, 2009		
PATH: KAST\		Kast_Waveplate.sch	