

MOTOR WIRE REMOVED FROM STAGE CABLES

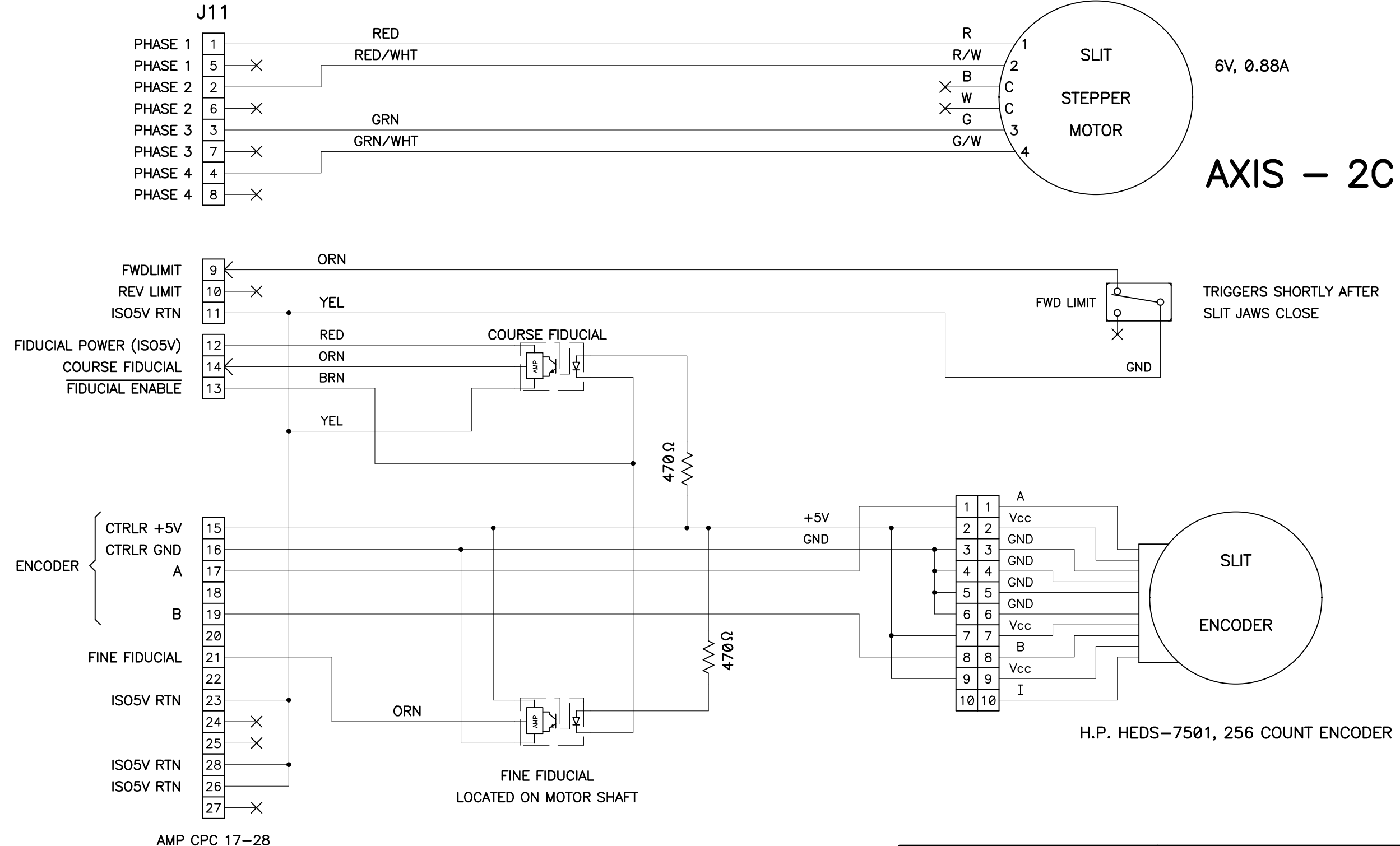

NOTE: ENCODER SIGNALS AND FIDUCIAL ENABLE SIGNALS ARE REFERENCED TO GALIL CONTROLLER POWER SUPPLY

UNIVERSITY OF CALIFORNIA LICK OBSERVATORY		SLIT STAGE KAST SPECTROGRAPH	
DES'N BY: T. Ricketts, B. Alcott	ORIGIN DATE: 06-07-06	DWG. NO.	NUM. 2 OF 2
Last SN	MODIFY DATE: 02-18-09	EL-3721	REV. B
PRINT TIME: 13:24:59	PRINT DATE: Wed Feb 18, 2009		
PATH: KAST\		Kast_Slit.sch	

REVISIONS	http://loel.ucolick.org/manual/KAST/schematics/KAST_Slit_sh_2.pdf
06-27-06	REV. B - TRANSALTED INTO PCAD, UPGRADE TO GALIL CONTROLLER
01-24-08	UPDATED TO GALIL DMC-4000 CONTROLLER
04-21-08	ADDED TWISTED PAIRS
05-02-08	MOVED HOME SENSOR LED POWER TO GALIL POWER SUPPLY FOR PROPER REFERENCE
01-21-09	CHANGED WIRING SO THAT FINE FIDUCIAL IS WIRED TO THE ENCODER POWER. THE OUTPUT IS APPLIED TO THE INDEX INPUT
02-05-09	REMOVED REFERENCES TO TB-1 WHICH DOES NOT EXIST. CORRECTED LIMIT SWITCH WIRING
02-18-09	ADDED ENCODER INFORMATION