

CONTROLLER #2, AXIS E - H  
STAGE DEPENDANT PIN ASSIGNMENTS

J2 GENERAL I/O								EXT. I/O
AXIS	STAGE CONN	FWD LIM	REV LIM	(HOME) FIDUCIAL	MAN FWD	MAN REV	BRAKE/SWITCH	FIDUCIAL ENABLE
E	J13	36	22	7	2	32	41/18	2
F	J14	37	23	8	X	X	27/3	32
G	J15	38	24	9	X	X	X/X	18
H	J16	39	25	10	X	X	X/X	3

CONTROLLER 2

AXIS

- E GRATING SELECT
- F GRATING TILT
- G (NOT ASSIGNED)
- H (NOT ASSIGNED)

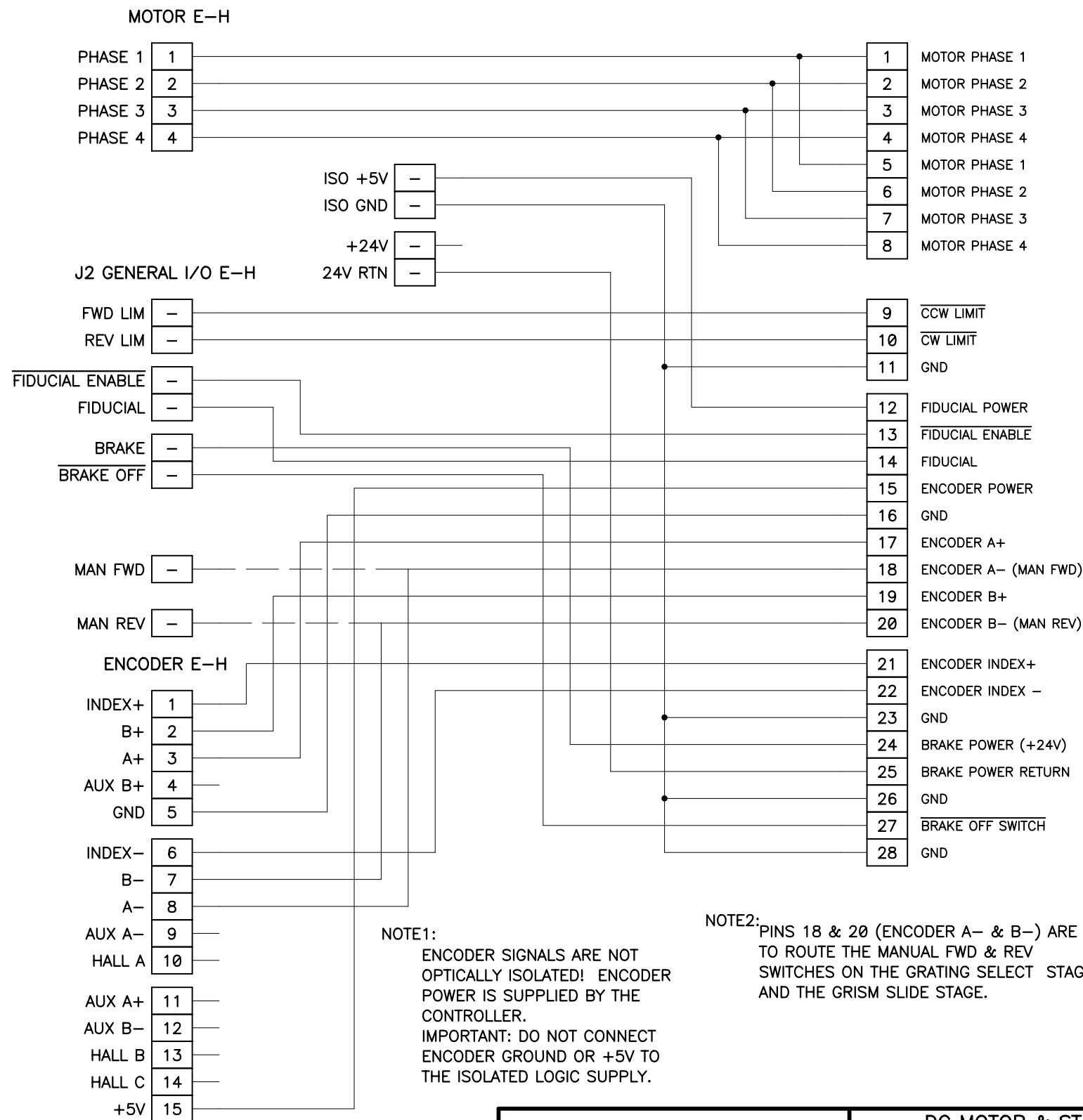

UNIVERSITY OF CALIFORNIA  
LICK OBSERVATORY

DC MOTOR & STAGE CABLE  
PIN ASSIGNMENTS  
KAST SPECTROGRAPH

REVISIONS

DES'N BY: B. Alcott	ORIGIN DATE: 06-08-06	DWG. NO.	NUM. 5 OF 5
Last SN	MODIFY DATE:	EL-3709	REV. B
PRINT TIME: 08:24:07	PRINT DATE: Fri Jan 09, 2009		
PATH: KAST\		Kast_Stage_Cable.sch	