

A-AXIS

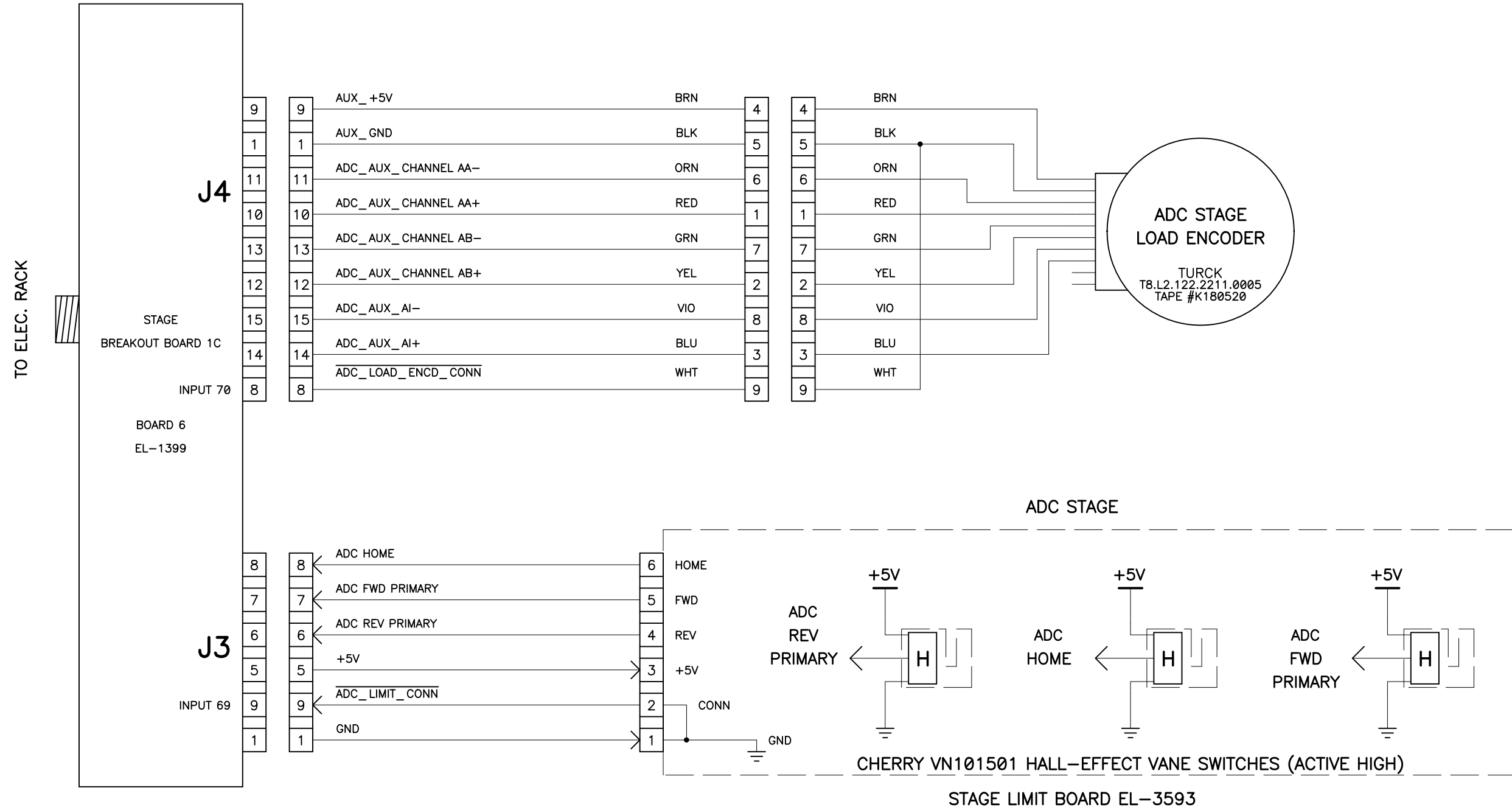

UNIVERSITY OF CALIFORNIA LICK OBSERVATORY		ADC STAGE APF SPECTROMETER	
DES'N BY: B. Alcott	ORIGIN DATE: 02-09-04	DWG. NO.	NUM. 3 OF 3
Last SN	MODIFY DATE: 11-28-11	EL-3511	REV. A
PRINT TIME: 09:47:07	PRINT DATE: Mon Nov 28, 2011		
PATH: APF\		APF_adc.sch	

REVISIONS

03-01-07 SPLIT SHEET 2 INTO TWO SHEETS

10-11-07 REPLACED BRUSHLESS MOTOR WITH REGULAR BRUSHED SERVOMOTOR

08-23-10 UPDATED TURICK LOAD ENCODER CABLE AND ADDED DB9 PINOUT BETWEEN BREAKOUT BOARD AND ENCODER

11-28-11 ADDED INPUT BIT INFO

http://loel.ucolick.org/manual/Apf/schematics/APF_adc_sh_3.pdf