

Revision	Date	Who	ECN #	Description of Change(s)
0.1	22-Apr-2008	MP/RB	-	Initial version.
0.2	02-Jul-2008	MP/RB	-	Correct pinout of linear regulator U12. Update BOM info in components P4, P11, P12, and P13.
0.3	14-Jul-2008	MP/RB	-	Corrected Sheet, Shutter Control.
0.4	16-Jul-2008	MP/RB	-	Split TRANSFER_GATE nets merged. Split MUX_GND_CAL nets merged
0.5	21-Jul-2008	MP/RB	-	Delete R112,R154,R171,R129. Change R160,R165,R118,R123 from 10K to 30.9K. Change R171,R129,R163,R168,R121,R126 from 91K to 30.9K. Change R132,R173 from 91K to 47.5K.

University of California, Lick Observatory		
1156 High Street Santa Cruz, CA 95064		
Title		
SCHEMATIC, PCB, FRONT PANEL INTERCONNECT		
Size	Document Number	Rev
B	EL-4211	0.5
Date: Thursday, July 24, 2008		
Sheet 1 of 11		

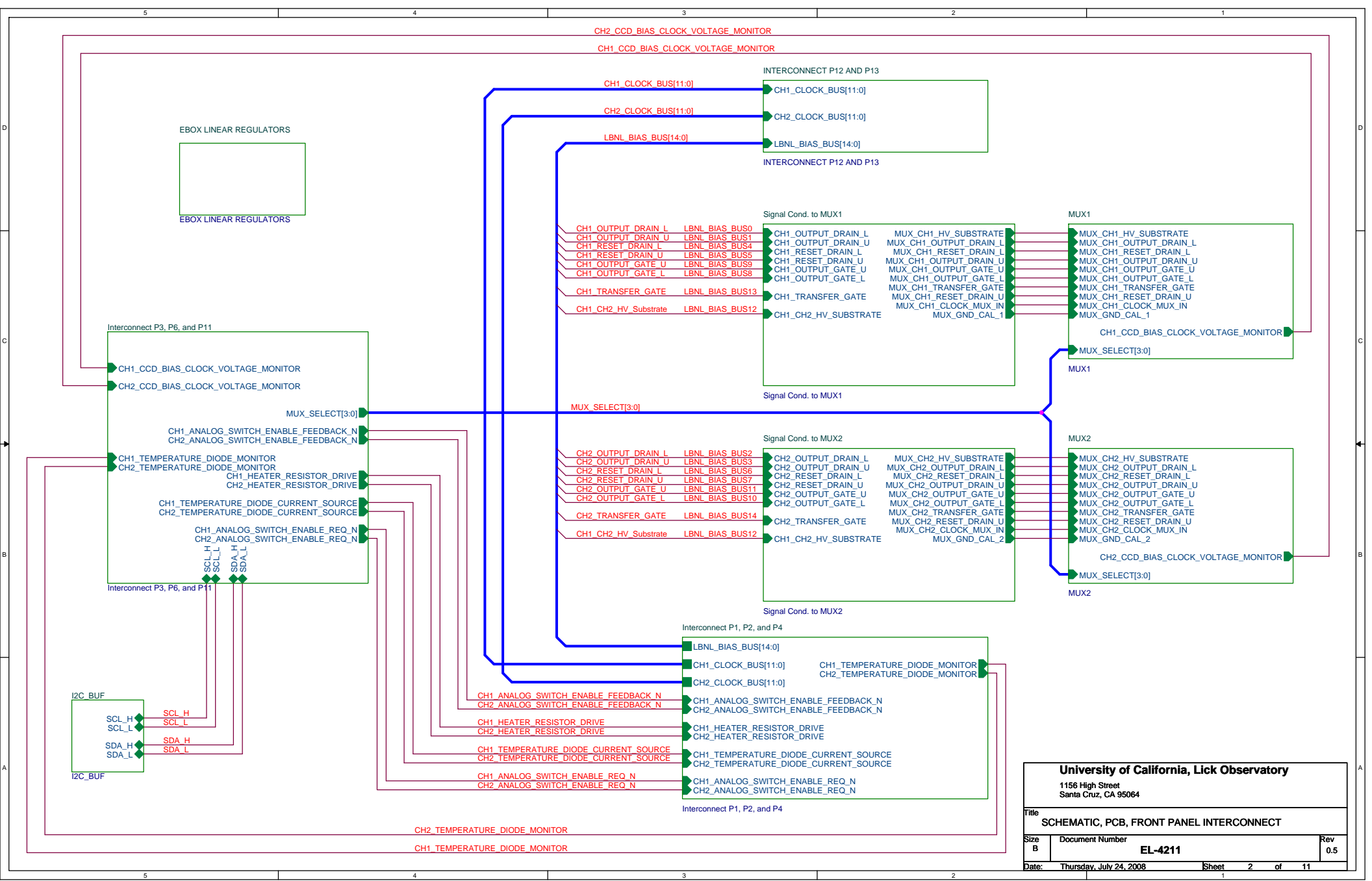

University of California, Lick Observatory
 1156 High Street
 Santa Cruz, CA 95064

Title: **SCHEMATIC, PCB, FRONT PANEL INTERCONNECT**

Size B	Document Number EL-4211	Rev 0.5
-----------	-----------------------------------	------------

Date: Thursday, July 24, 2008 Sheet 2 of 11

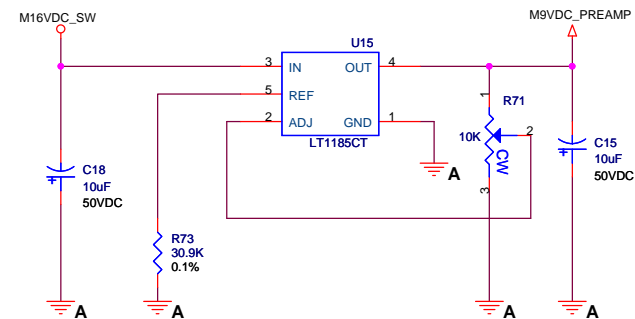
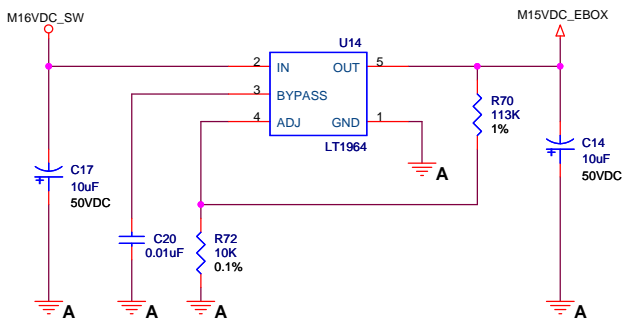
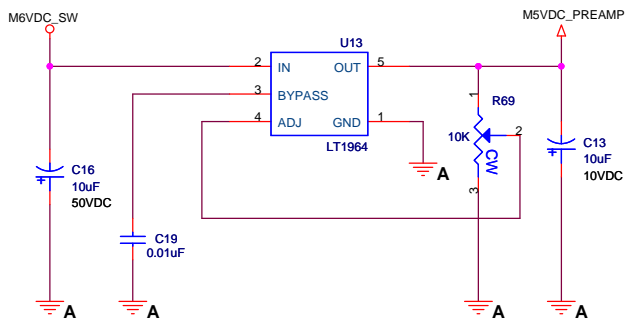
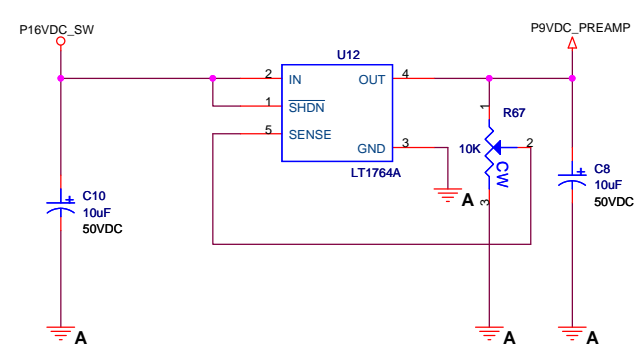
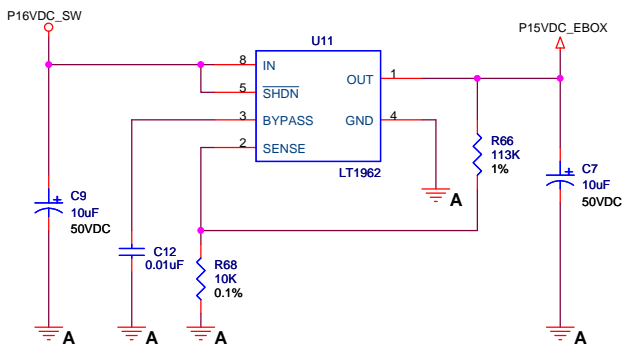
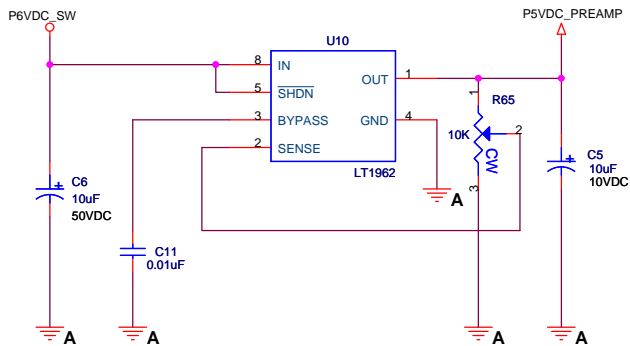

POWER IN FROM PMAc

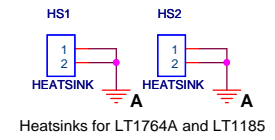
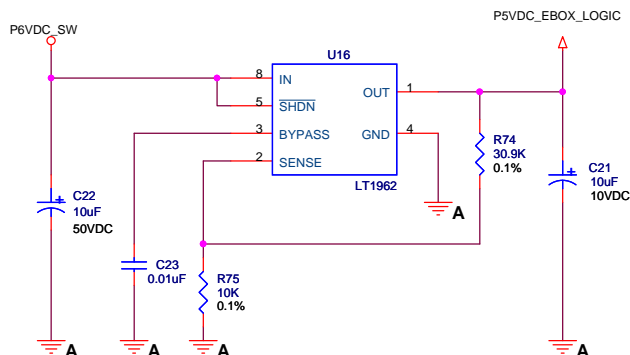
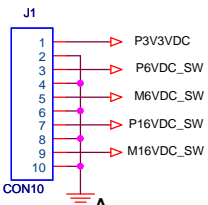

University of California, Lick Observatory		
1156 High Street Santa Cruz, CA 95064		
Title: SCHEMATIC, PCB, FRONT PANEL INTERCONNECT		
Size: B	Document Number: EL-4211	Rev: 0.5
Date: Thursday, July 24, 2008	Sheet: 3	of 11

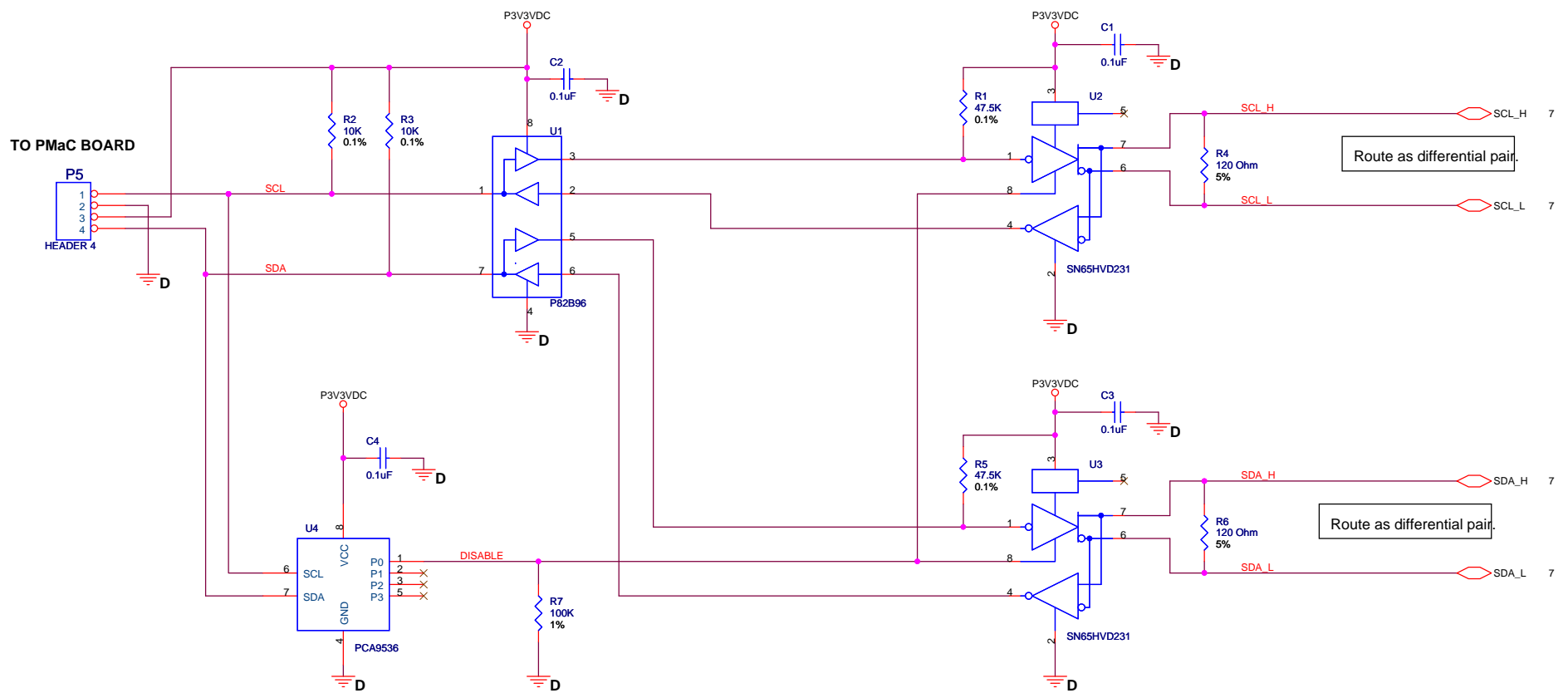

NOTE:

GPIO: D0 = 1
 GPIO_DIR_0:
 0 = OUT = DISABLE
 1 = INPUT = ENABLE

GPIO_OUT D0 = 0:
 OUT = ENABLE SLOPE CONTROL OFF

University of California, Lick Observatory
 1156 High Street
 Santa Cruz, CA 95064

Title: SCHEMATIC, PCB, FRONT PANEL INTERCONNECT

Size B	Document Number	Rev 0.5
EL-4211		

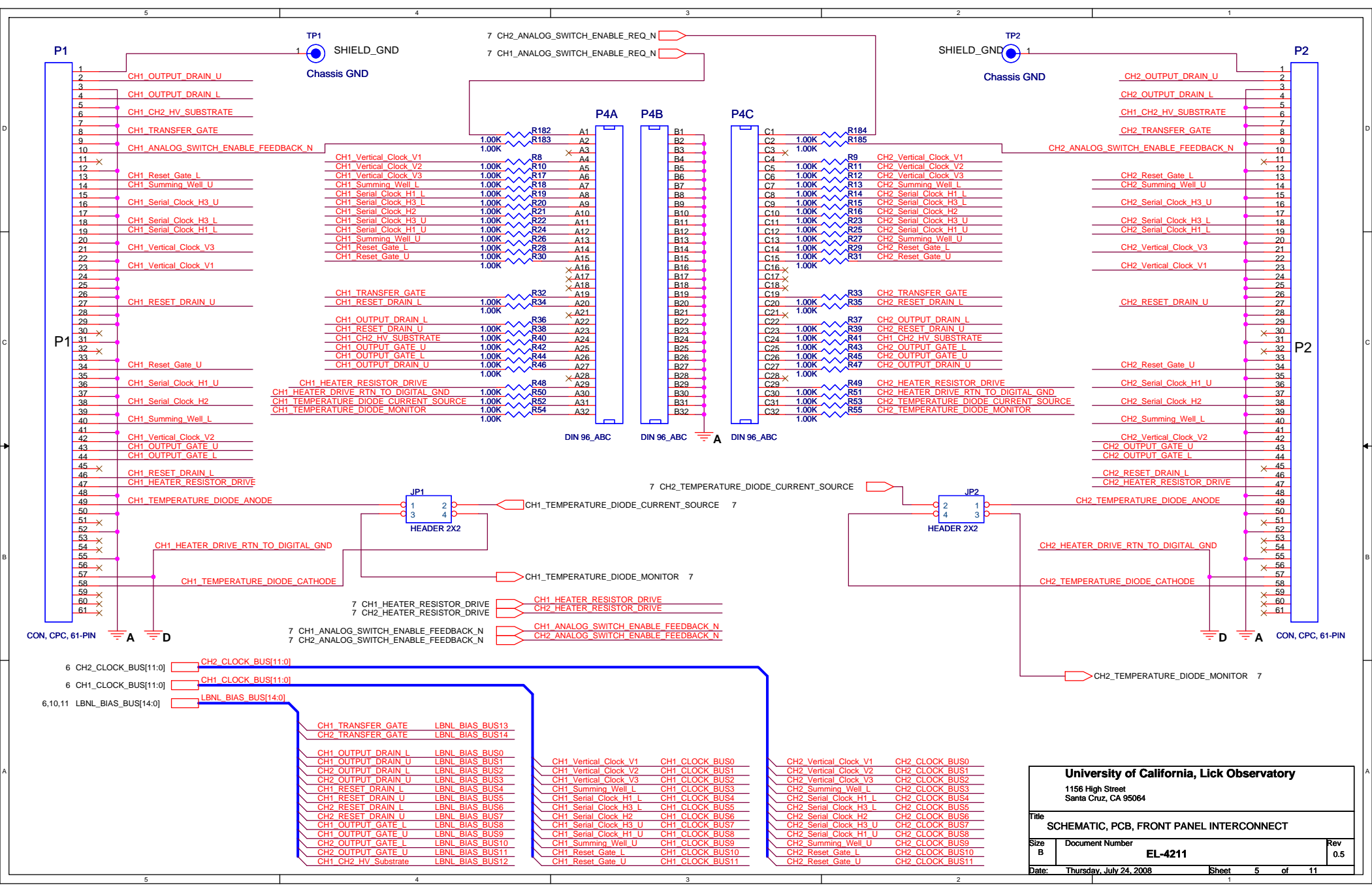

University of California, Lick Observatory
 1156 High Street
 Santa Cruz, CA 95064

Title: SCHEMATIC, PCB, FRONT PANEL INTERCONNECT

Size B Document Number **EL-4211** Rev 0.5

Date: Thursday, July 24, 2008 Sheet 5 of 11

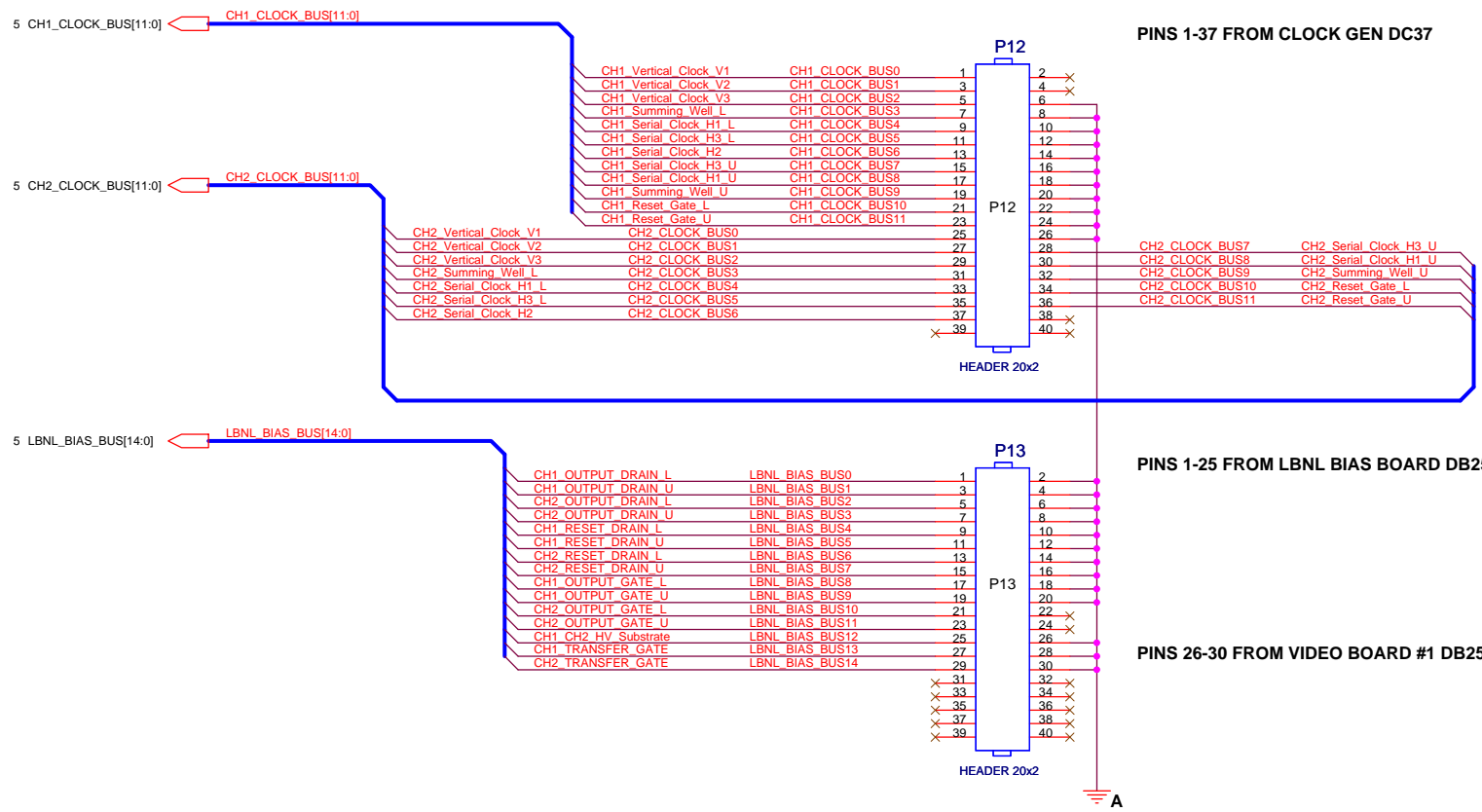

PINS 1-37 FROM CLOCK GEN DC37

PINS 1-25 FROM LBNL BIAS BOARD DB25

PINS 26-30 FROM VIDEO BOARD #1 DB25

University of California, Lick Observatory		
1156 High Street Santa Cruz, CA 95064		
Title SCHEMATIC, PCB, FRONT PANEL INTERCONNECT		
Size B	Document Number EL-4211	Rev 0.5
Date:	Thursday, July 24, 2008	Sheet 6 of 11

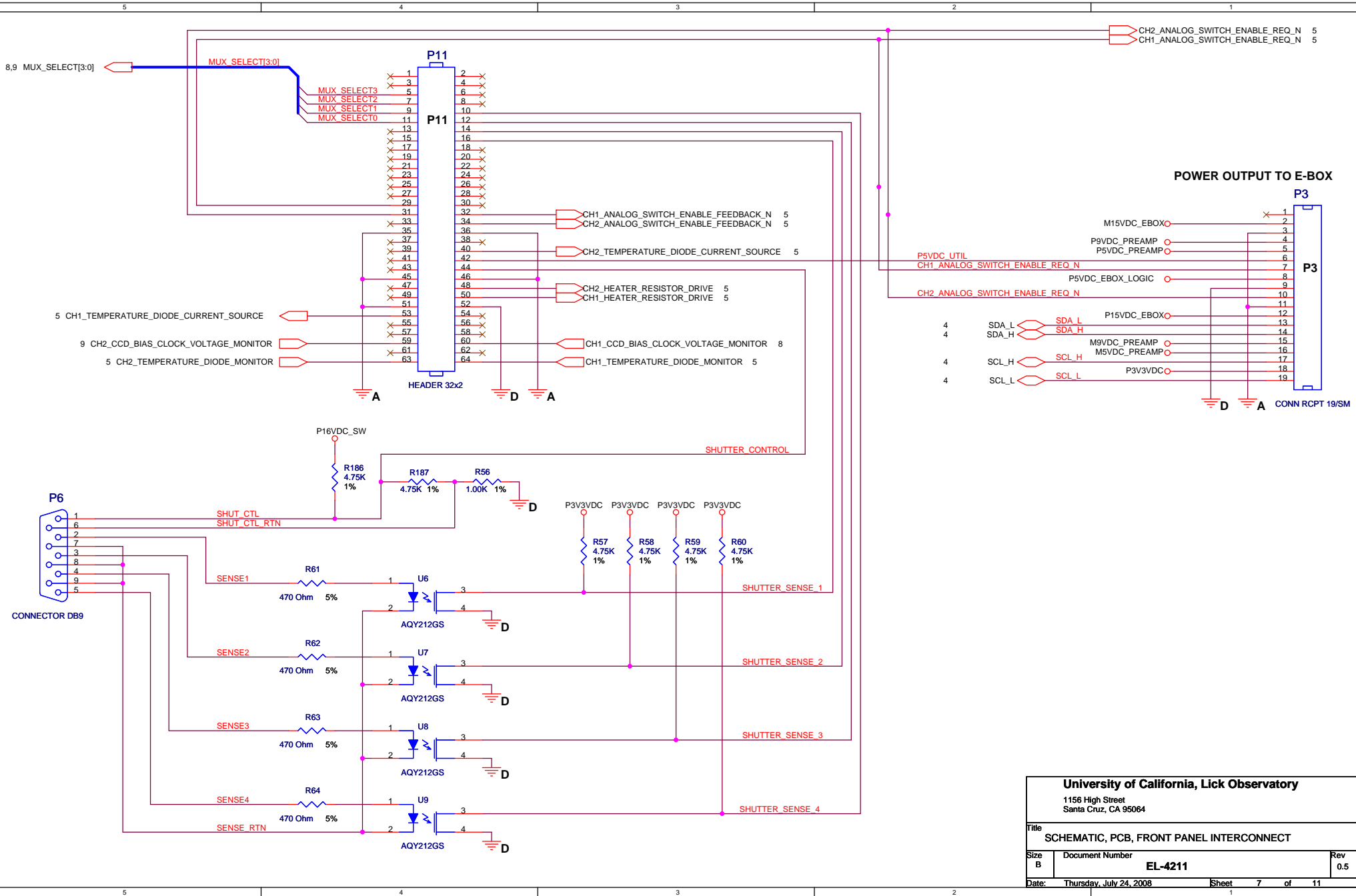

University of California, Lick Observatory		
1156 High Street Santa Cruz, CA 95064		
Title: SCHEMATIC, PCB, FRONT PANEL INTERCONNECT		
Size: B	Document Number: EL-4211	Rev: 0.5
Date: Thursday, July 24, 2008	Sheet: 7	of: 11

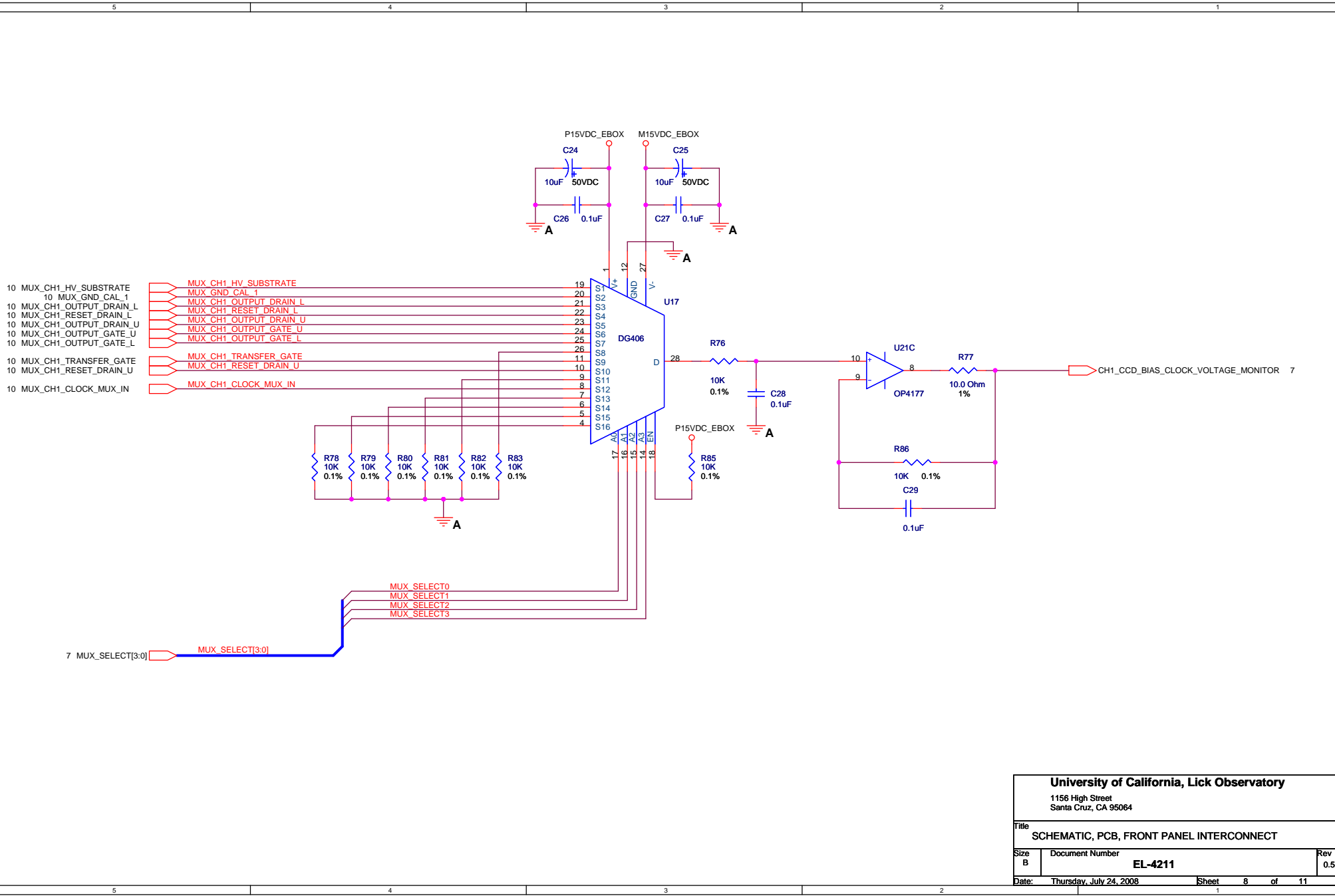

University of California, Lick Observatory		
1156 High Street Santa Cruz, CA 95064		
Title SCHEMATIC, PCB, FRONT PANEL INTERCONNECT		
Size B	Document Number EL-4211	Rev 0.5
Date: Thursday, July 24, 2008		
Sheet 8 of 11		

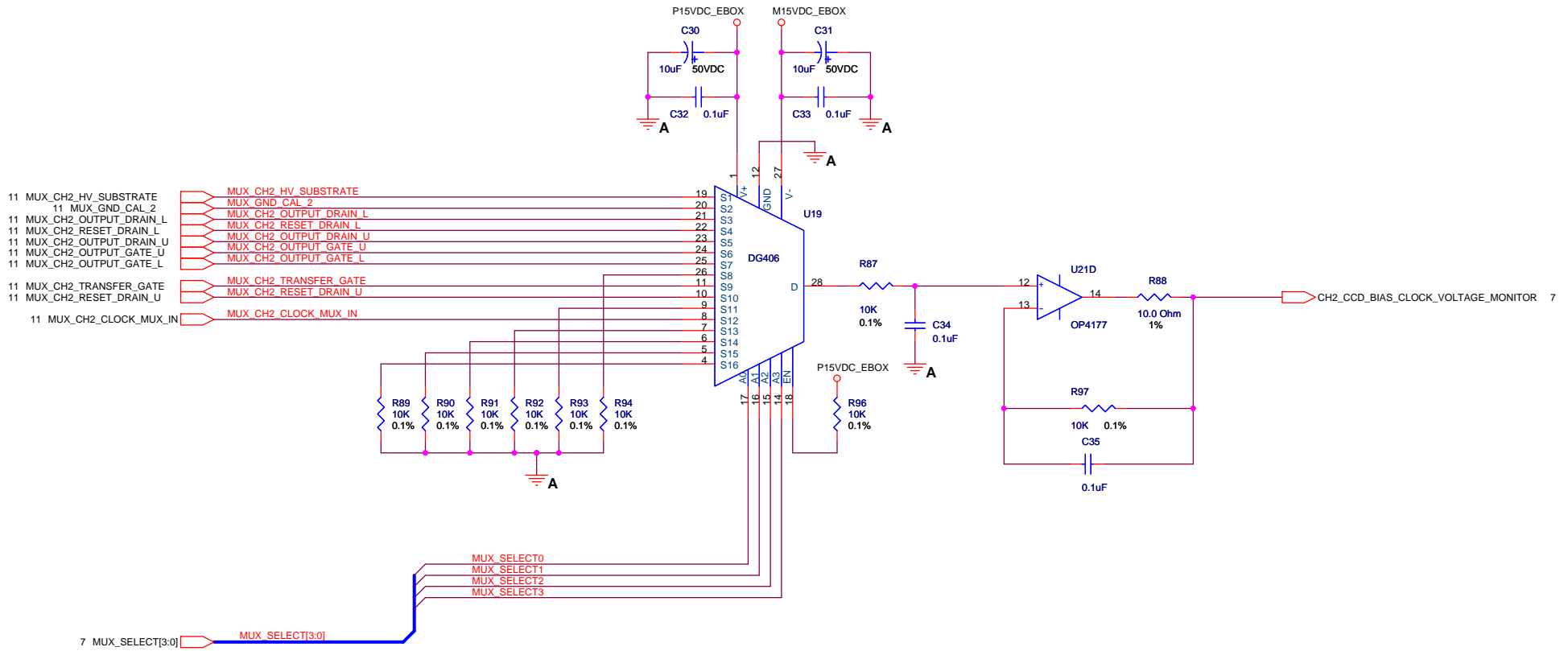

University of California, Lick Observatory		
1156 High Street Santa Cruz, CA 95064		
Title: SCHEMATIC, PCB, FRONT PANEL INTERCONNECT		
Size: B	Document Number: EL-4211	Rev: 0.5
Date: Thursday, July 24, 2008	Sheet: 9	of 11

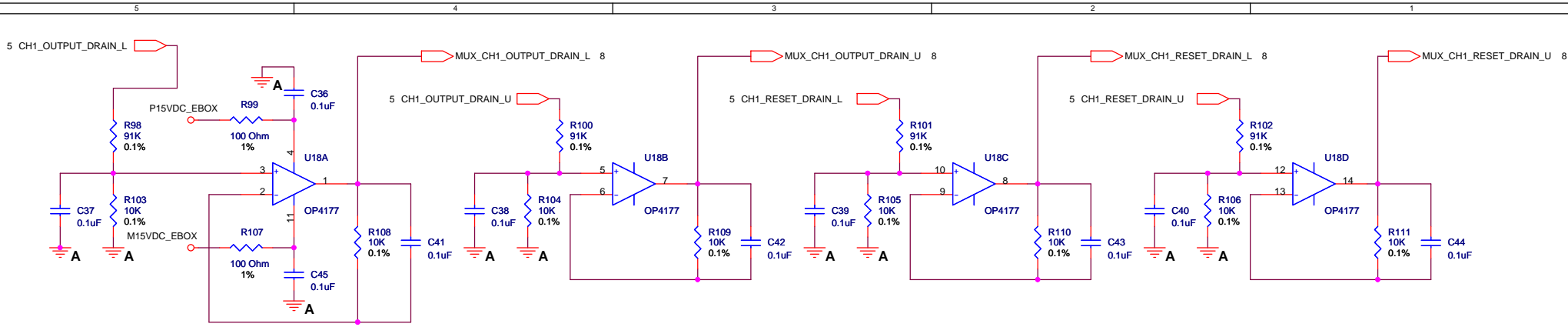

CH1_CLOCK_MUX_IN

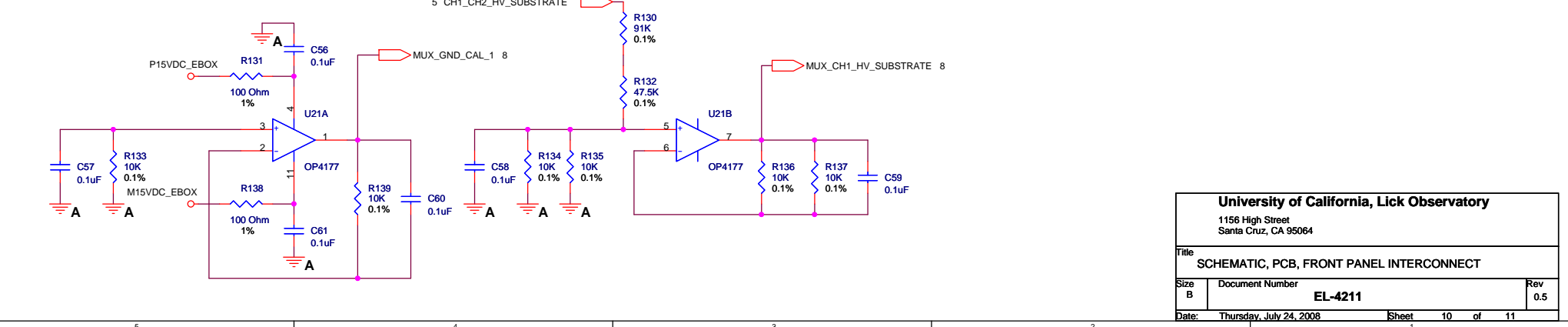
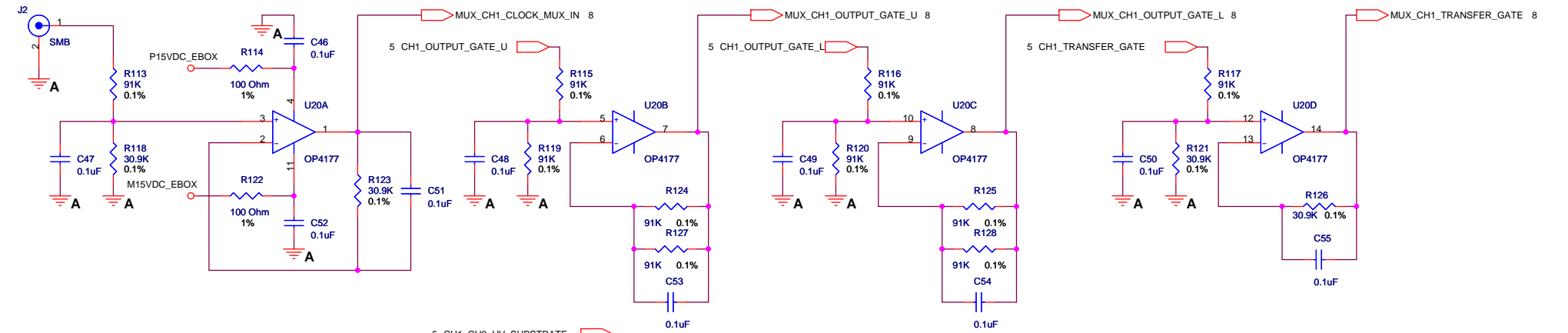

University of California, Lick Observatory		
1156 High Street Santa Cruz, CA 95064		
Title: SCHEMATIC, PCB, FRONT PANEL INTERCONNECT		
Size: B	Document Number: EL-4211	Rev: 0.5
Date: Thursday, July 24, 2008	Sheet: 10	of 11

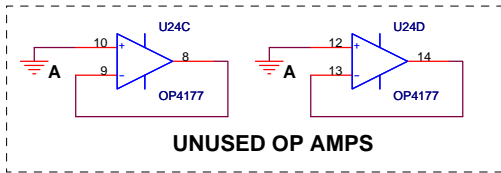
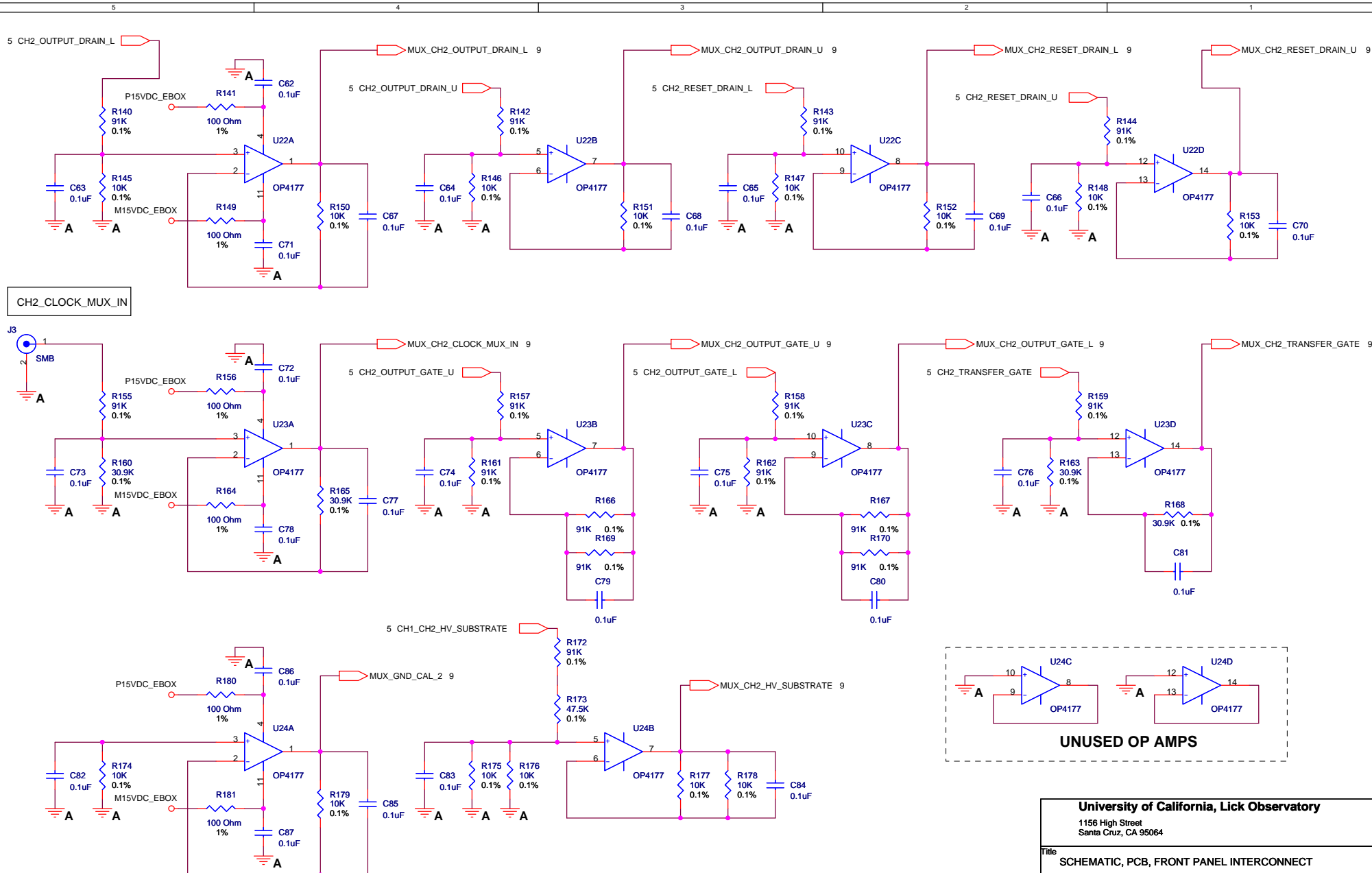

University of California, Lick Observatory		
1156 High Street Santa Cruz, CA 95064		
Title: SCHEMATIC, PCB, FRONT PANEL INTERCONNECT		
Size: B	Document Number: EL-4211	Rev: 0.5
Date: Thursday, July 24, 2008	Sheet: 11	of 11