

CABLE CONNECTED SIGNALS

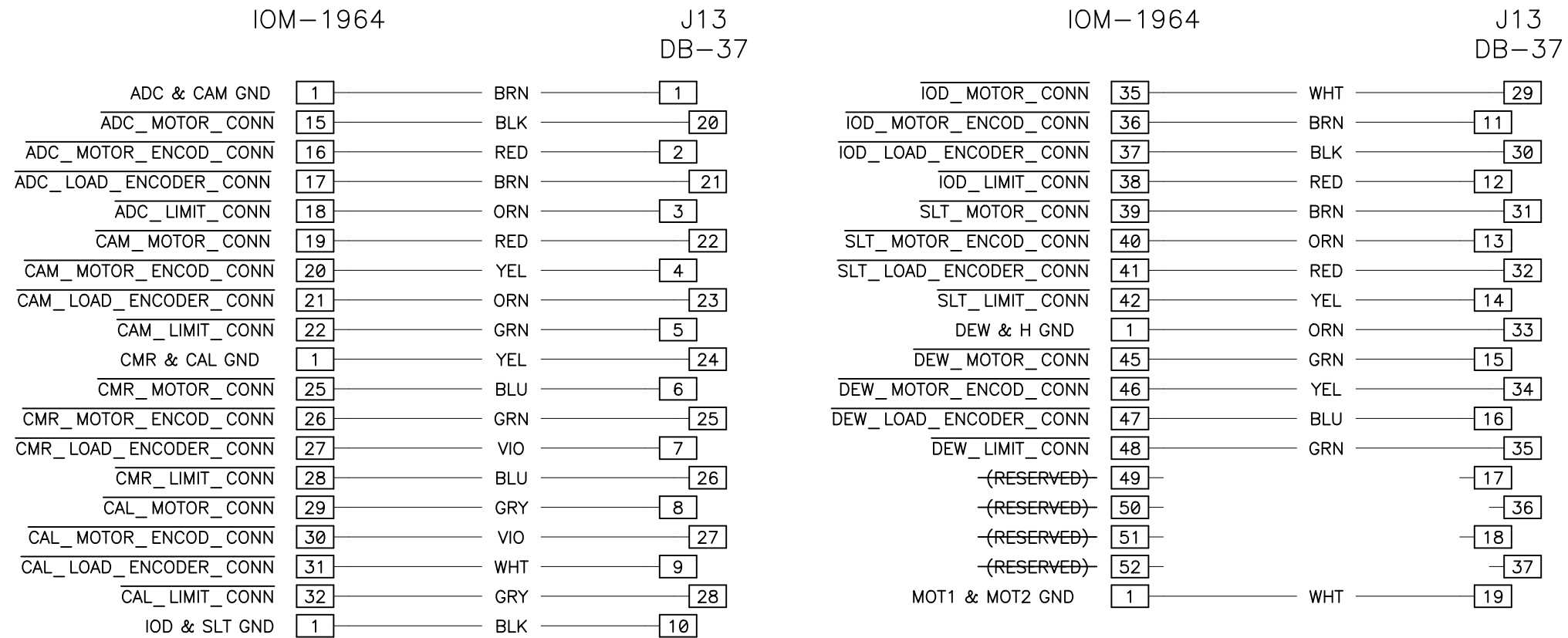

SECONDARY LIMIT SIGNALS

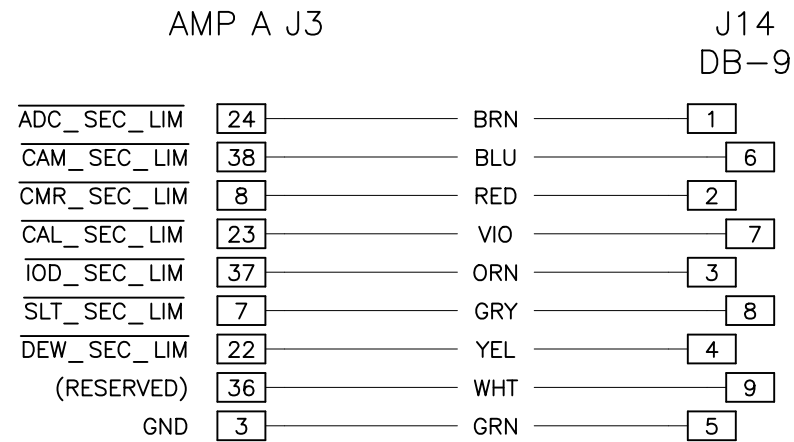

UNIVERSITY OF CALIFORNIA LICK OBSERVATORY		APF ELECTRONICS INTERCONNECTIONS CABLE CONN, 2nd LIMITS	
DES'N BY: B. Alcott	ORIGIN DATE: 09-08-05	DWG. NO.	NUM. 4 OF 9
Last SN	MODIFY DATE: 05-02-07	EL-3508	REV. C
PRINT TIME: 11:00:29	PRINT DATE: Mon May 17, 2010		
PATH: APF/		APF_interconnections.sch	

REVISIONS http://loel.ucolick.org/manual/Apf/schematics/APF_interconnections_sh_4.pdf

09-29-05 ADDED THIS SHEET TO SHOW INTERNAL CONNECTORS
 05-15-06 ADDED LABELS TO GNDS ON DB37
 05-02-07 REALLOCATED RESERVED INPUT SIGNALS TO POWER SUPPLY INPUTS - SEE SHEET 7