

LOCAL/REMOTE WIRING DETAILS

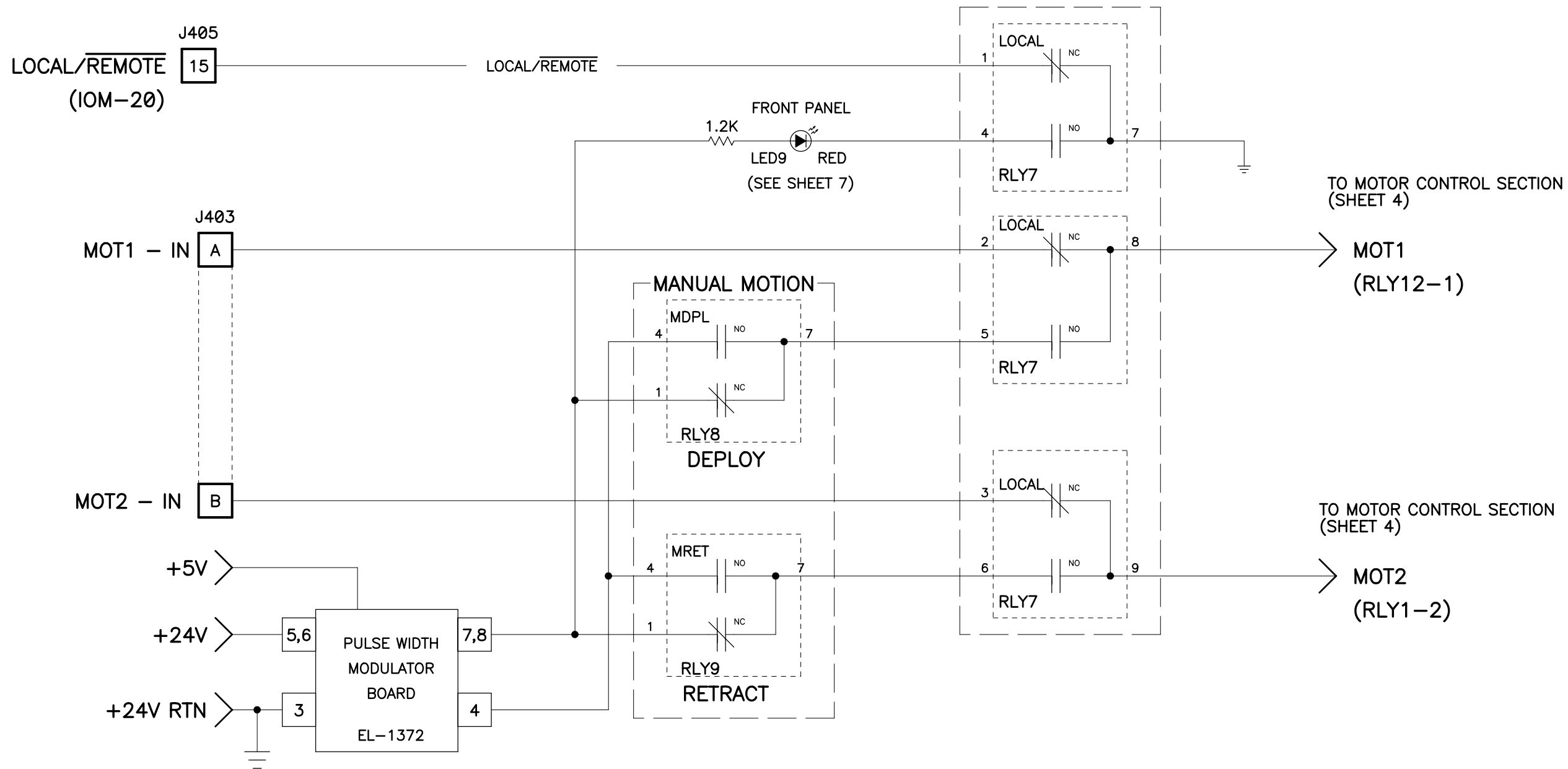

MANUAL PADDLE

LOCAL/REMOTE CIRCUIT SHOWN HERE FOR CLARITY

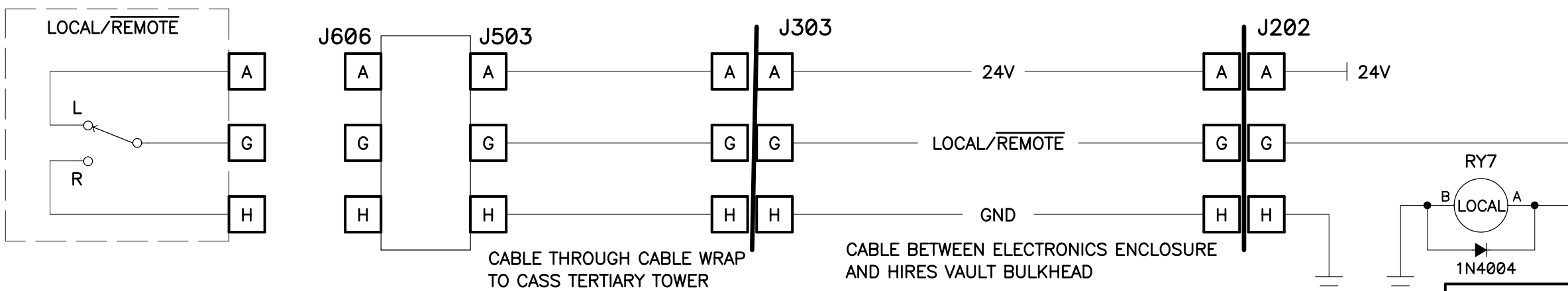

REVISION	
09-08-04	ADDED RELAY DESIGNATORS
10-12-04	ADDED LABEL (LED9) AND NOTE TO FRONT PANEL LED AND NO-NC LABELS TO RELAY CONTACTS
12-21-04	ADDED PWM BOARD BACK INTO THE SYSTEM
01-05-05	SWAPPED + AND - VOLTAGE CONNECTIONS TO RLY8 AND RLY9 TO CHANGE DIRECTION OF MOTION VIA MANUAL PADDLE
03-12-07	CORRECTED HAND PADDLE WIRING AND LOCAL/REMOTE LABELS

UNIVERSITY OF CALIFORNIA LICK OBSERVATORY		KECK ADC LIMIT INTERLOCK	
DES'N BY: B. Alcott	ORIGIN DATE: 10-03-03	DWG. NO.	NUM. 5 OF 8
Last SN	MODIFY DATE: 03-12-07	EL-3612	REV. B
PRINT TIME: 08:20:47	PRINT DATE: Mon Mar 12, 2007	PATH: ADC\	
ADC_interlock.sch			